

NOTES:

1. GENERAL SPECIFICATIONS: BIVAR MOLDED COMPONENT SPECIFICATION BV00-E101.
2. MATERIAL: NYLON 6/6, 94V-0, BLACK.

REVISIONS			
REV.	DESCRIPTION	DATE	APPROVED
C	Production Release	2/18/2002	E.M.
D	Re-Specify Inspection Dimension	3/13/2003	M.C.
E	Engineering Update w/o Changes	3/8/2004	M.C.
F	Removed Material Code	4/9/2017	J.C.
G	ECO-1241: Updated mounting holes	3/20/2024	A.V.

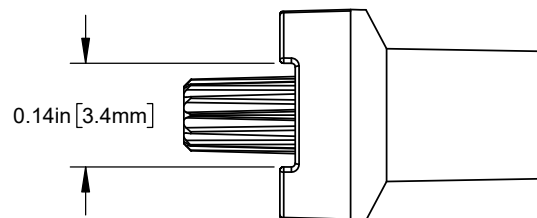
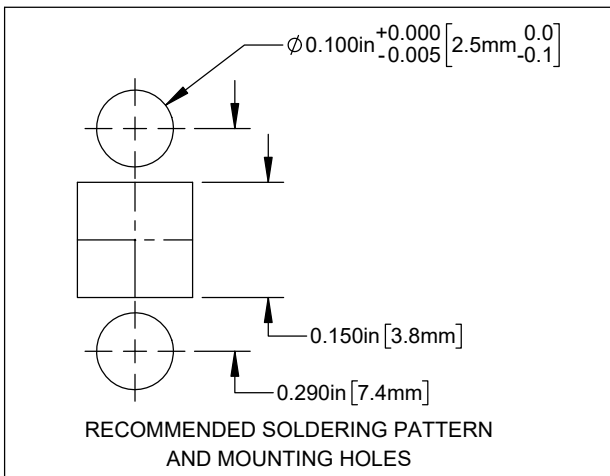
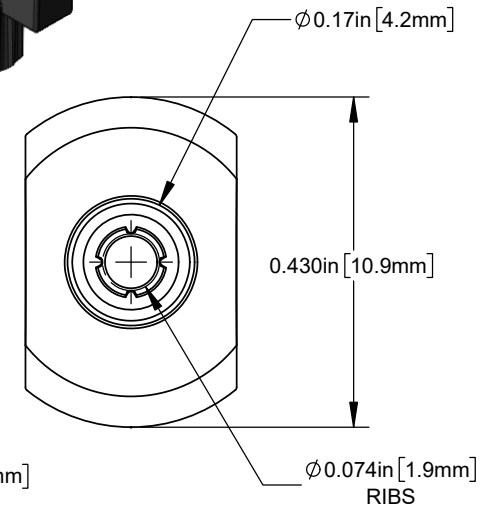
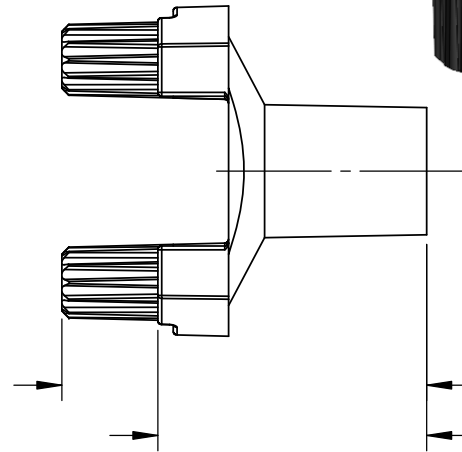
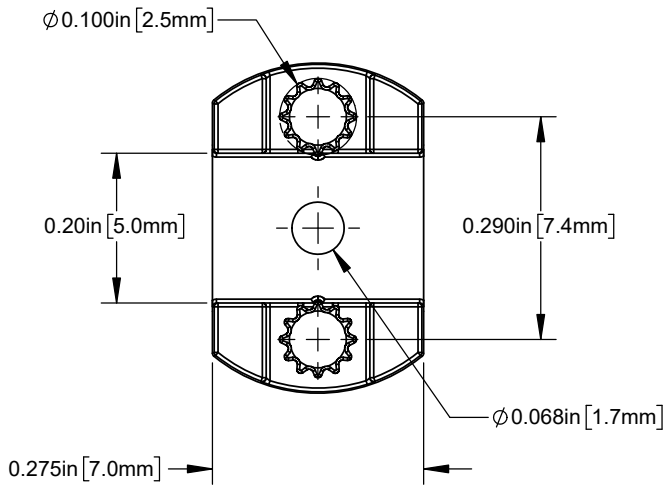
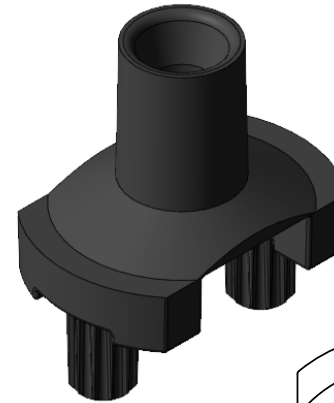

CUSTOMER USE DRAWING

STANDARD TOLERANCE (UNLESS OTHERWISE SPECIFIED)		 4 THOMAS, IRVINE, CA. 92618 TEL: (949) 951-8808 FAX: (949) 951-3974	
DECIMALS	ANGULAR		
.X ± .1	X° ± 1°	TITLE: ADAPTER, SURFACE MOUNT FLEXIBLE LIGHT PIPE	
.XX ± .01			
.XXX ± .005		DRAWING NO: SMFLP	REVISION: G
DESIGNED: M. CHEN	DATE: 1/15/2002	SHEET SIZE: A	CAGE CODE: 32559
REVISOR: K. BARON	DATE: 3/20/2024		
CHECKED: A. VALDEZ	DATE: 3/20/2024	SCALE: 4:1	SHEET # 1 OF 1
CAD GENERATED DOCUMENT, DO NOT MEASURE DRAWING			