

ITEM	Q'TY	PART NUMBER	PART DESCRIPTION
1	1	LP-4H	Shell, 4 High, Right Angle Light Pipe
2	1	LP-4EP	Light Pipe, 4 High, Right Angle, Extend Profile

REV.	DESCRIPTION	DATE	APPROVED
B	Engineering Update w/o Changes	03/08/04	M. C.
C	Added Note	05/16/08	M. C.
D	Engineering Update w/o Changes	03/22/16	J. C.

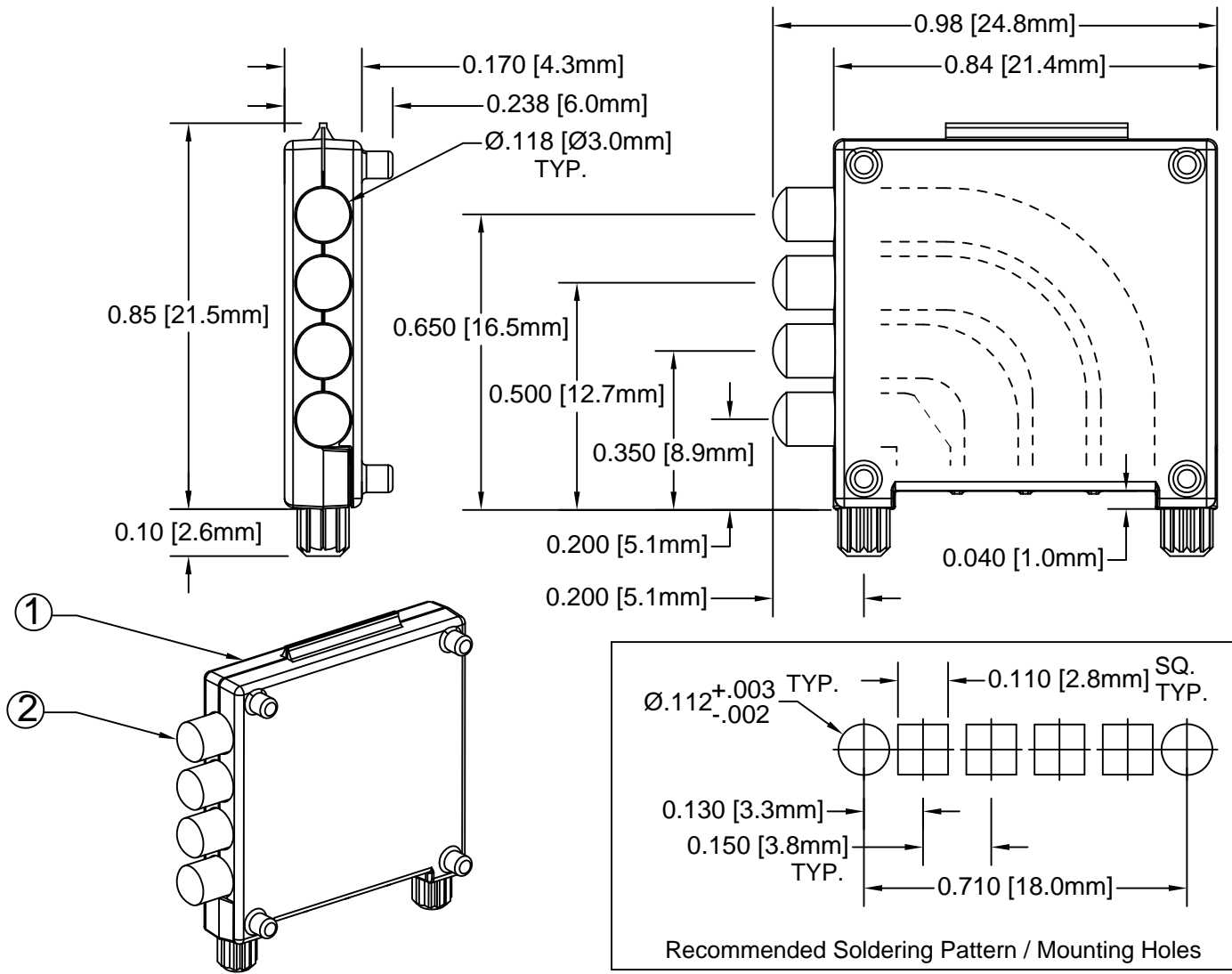

Note: Pre-Assembled and Ultrasonically Welded

STANDARD TOLERANCE (UNLESS OTHERWISE SPECIFIED)		BIVAR®	
DECIMALS	ANGULAR	4 THOMAS, IRVINE, CA. 92618	
.X ± .1	X° ± 1°	TEL: (949) 951-8808 FAX: (949) 951-3974	
.XX ± .02		TITLE: QUAD-LEVEL LIGHT PIPE ASSEMBLY, EXTENDED LENS	
.XXX ± .010		PART NO: LP4-EP	REVISION: D
DESIGNED: Michael Chen	DATE: 08/26/02	CAGE CODE : 32559	SHEET # 1 OF 1
CHECKED: S. Irving	DATE: 08/26/02	CAD GENERATED DOCUMENT. DO NOT MEASURE DRAWING.	